

ARCTIKO Flexaline LFE 125

true cooling specialists



BIOMEDICAL FREEZER

With its low energy consumption, our eco-friendly Flexaline series offers an excellent level of flexibility, security, and reliability. Track your temperature data continuously with our digital controller which features an intergrated data logger.

▶ EXTRA SECURITY

- High/low temperature alarms and open-door alarms with audio and visual indication.
- Data logger for continuous temperature tracking.
- Backup battery for the digital controller and data logger during a possible power failure.
- Built-in lock with keys to restrict access to the stored samples.

▶ FLEXIBILITY

- The position of the shelves are easily adjustable for your storage needs.
- Easy positioning on uneven floors using four integrated leveling feet.
- Reversible glass door coming with the left-handed opening as a default.

▶ OTHER BENEFITS

- LED light can be customized for all-the-time lighting, even when the refrigerator doors are closed.
- USB port for extracting logged data.
- Remote alarm interface.
- Porthole for inserting your own temperature monitoring equipment.
- Air-forced cooling for maximum temperature uniformity, stability and quick temperature recovery following door openings.



LFE 125



The digital controller features visual and acoustic alarms, high/low-temperature alarms, open-door alarms and a data logger.

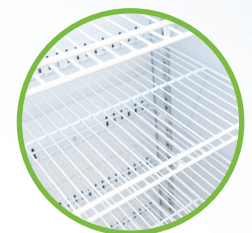

The shelves are easily adjustable to offer the best flexibility for your storage needs.



All models in our Flexaline range feature durable, cost saving LED lighting for better overview of your samples.



DATA LOGGER



USB PORT



AIR FORCED COOLING



ADJUSTABLE SHELVES



VARIOUS SAFETY FEATURES

* The pictures shown are for reference only, actual product size may vary. Please read the dimensions of the product in the specifications.

The ARCTIKO Flexaline series includes the following features, and more:

- Eco Friendly Refrigerant
- 100% HCFC & CFC FREE
- Low Energy Consumption
- Adjustable Shelves
- Key Lock on Door
- Remote Alarm Interface

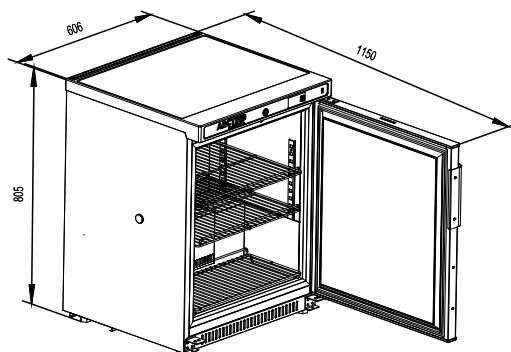
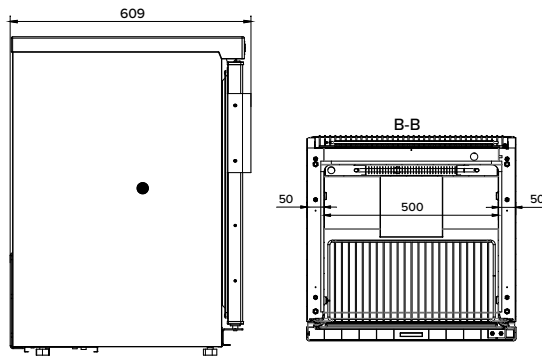
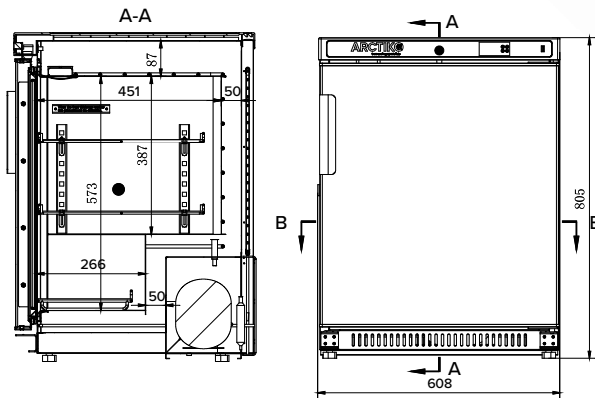

MODEL	LFE 125
Main specifications	
Item code	19000035-01
Temperature range (°C)	-25°C to -10°C
Ambient temperature (°C)	16°C to 32°C
Capacity (L)	[118 / 118]
Exterior dimensions WxDxH (mm)	608×610×805
Interior dimensions WxDxH (mm)	500×450×570
Weight (KG)	43
Insulation (mm)	50
Cooling technology	Static cooling
Controller model / probe type	Honker / NTC
Power	
Power supply (V)	230
Frequency (Hz)	50/60
Power consumption (kWh/24h)	2,0
AMP (A)	2,0
Power (Watt)	130
Horsepower (HP)	1/6
Alarm functions	
Alarm (displayed as text, not codes)	No
Visual / acoustic alarm	Yes / Yes
Power failure alarm	Yes
Adjustable high / low-temperature alarm	Yes / Yes
Open door alarm	Yes
Probe failure alarm	Yes
Low battery alarm	Yes
Compressor failure alarm	No
Data logging & external connection	
Voltage-free contact for remote alarm (e.g. GSM alarm module)	Yes
Electronic data logger	Yes
USB port for software update & data download	Yes
Temperature chart recorder	No
Display features	
Display type	Digital
Number of optional reference probes	N/A
Password protection for turning unit on / off	No
Temperature graph on display	No
Other features	
Automatic defrost	No
Antifreeze function	No
Vacuum release port	No
Access port for external probe etc. (int. diameter mm)	20
Light	Yes
Lock with key	Yes
Castors (total pcs) / castors with brake (pcs)	No
Fixed feet (pcs) / levelling feet (pcs)	4 / 4
Sub lids / inner doors (pcs)	No
Reversible door(s)	Yes
Fixed shelves (pcs) / adjustable shelves (pcs)	0 / 3
Max. no. of shelves (pcs) / recommended max. no. of shelves (pcs)	3 / 3
Max load per shelf (kg)	19
Adjustable drawers (pcs)	N/A
Max. no. of adjustable drawers (pcs)	N/A
Max. load per adjustable drawer (kg)	N/A
Max. no. of blood bags - by standard no. of adj. drawers (pcs)	N/A
Max. no. of blood bags - by max. no. of adj. drawers (pcs)	N/A
Refrigeration & cabinet	
Number of compressors	1
Refrigerant	R290
Interior cabinet material	Powder coated aluminum plate
Exterior cabinet material	Powder coated galvanized steel
Colour (exterior cabinet)	White
Foam type	Cyclopentane
VIP vacuum insulated panels	No
Shipping	
Shipping weight (kg)	51
Shipping dimensions WxDxH (cm)	66x67x95
Shipping volume (m ³)	0,4